

M1500

2021-06

USER MANUAL V1.2

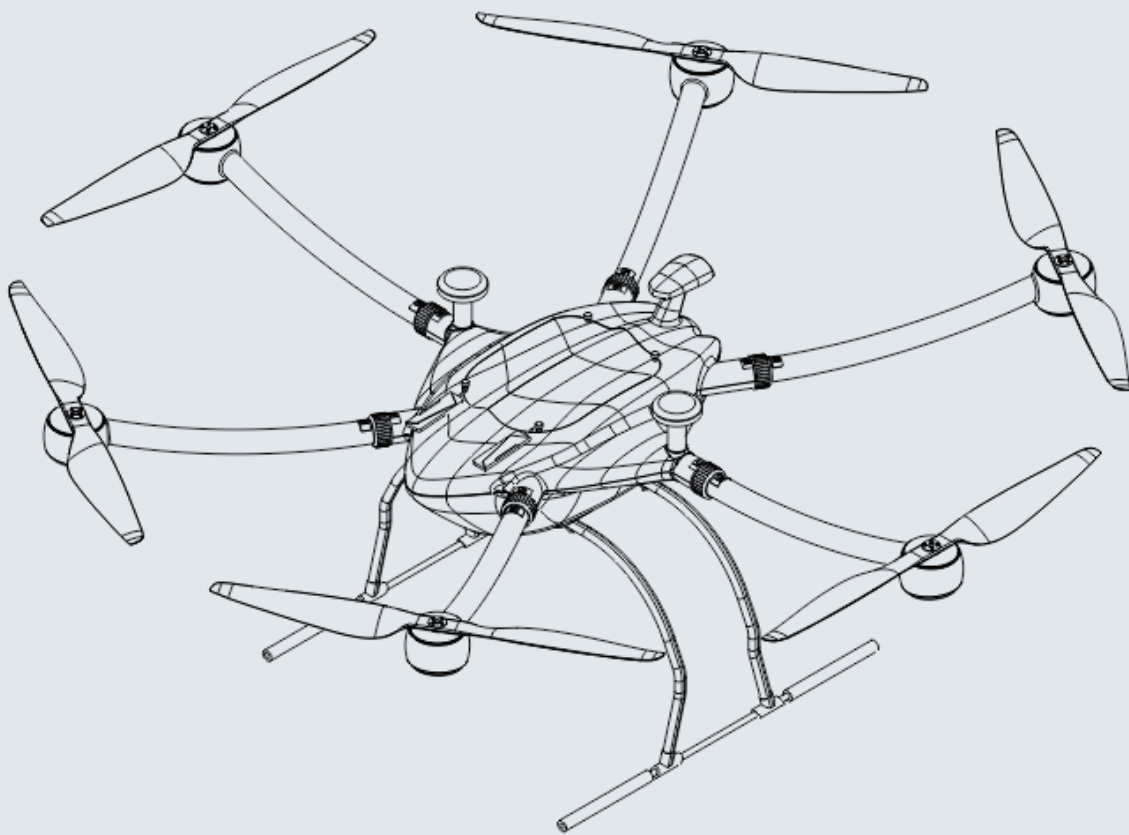

TECHNICAL SUPPORT

T-DRONES® | 2021

01 INTRODUCTION

Being a platform of ultra-light, long endurance and multiple applications, this aircraft can be employed for various missions with corresponding equipment including aerial photography, mapping and surveying, meteorological monitoring, surveillance, military supervision and geoexploration etc. Custom solutions are also available.

02 FEATURES

- Ultra-light materials and structural optimization to obtain longer flight time.
- The low center of gravity design makes the aircraft more reliable.
- The special-shaped design of the arm root makes the main structure safer and more reliable.
- The arms and landing gears can be folded and disassembled quickly.
- Chute design for easy installation of battery.
- No tools required. Only 10 minutes to get ready to fly.

03 SPECIFICATIONS

Wheelbase	1600mm	Disassembly	Quick detach
AUW	23kg	Payload	5~10kg
Flight Time	5kg Payload ≥ 55mins; 10kg Payload ≥ 41mins	Flight Range	10km
Flight Altitude	100~1000m (Typical); 6500m asl. (Max.)	Flight Speed	10~35km/h (Typical); 65km/h (Max.)
Wind Resistance Level	Force 5	Propulsion System	T-MOTOR 8112 KV110 & FLAME 60A 12S & GL30*10.5
Battery	New solid 6S 30Ah	FC	Compatible with A3, PIX and Micropilot

04 DISCLAIMER

Due to the difficulty and danger in operation of this product, it is prohibited for people under 18 years old to use it. Please do keep out of children's reach, and be cautious when operating this product in places where children are present.

Before using this product, please read this document carefully to understand your legal rights, responsibilities and safety instructions; otherwise, property losses, safety accidents and personal safety hazards may be caused. Once you use this product, it is deemed that you have understood, approved and accepted all the terms of this statement. The user is responsible for his/her actions and all consequences arising therefrom. The user promises to use this product only for legitimate purposes, and agrees to the terms and other related policies and guidelines.

T-DRONES shall not be responsible for any losses caused by users not using the product in accordance with this manual.

Within the framework permitted by the law, T-DRONES shall not be liable for any indirect, punitive, or incidental damages (including the losses suffered by you due to the purchase, use or inability to use this product).

When using this product, it is necessary to fully understand the relevant specifications and regulations, and to use it with caution. T-DRONES shall not be liable for any third-party personal or property damage

caused by a flight accident. T-DRONES has the final right to interpret the above permitted by laws and regulations. T-DRONES reserves the right to update, revise or terminate this manual and the disclaimer without prior notice.

05 PRECAUTIONS

Rotating props on operating M1500 can cause serious injuries. Please make sure to keep a safe distance from the aircraft.

- ALWAYS make sure to stay away from insecurity factors, such as obstacles, people and power lines.
- NEVER get close to rotating motors and props to avoid injuries.
- NEVER overload the aircraft.
- ALWAYS make sure that motors and props are correctly mounted.
- ALWAYS make sure all parts are in good condition before flying.
- ALWAYS make sure the aircraft is well balanced if you are to fly without payload.

06 ASSEMBLY

1.Content (Figure 1)

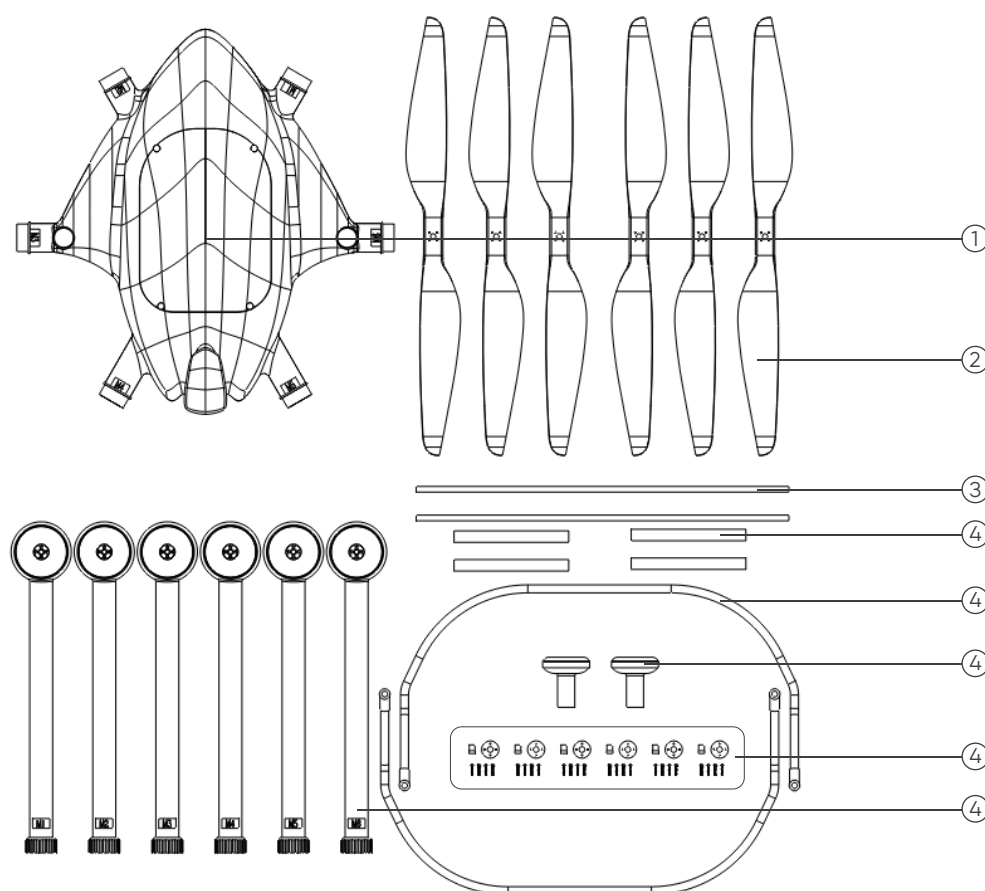

(Figure 1)

- | | | | |
|-----------------------------|-------------------------|-------------------|------------------------------|
| ① Body: 1pc | ② Propeller: 3 Pairs | ③ Arm: 6 pcs | ④ Landing gear parts: 2 sets |
| ⑤ Landing gear tube: 2 pcs | ⑥ Shock absorber: 4 pcs | ⑦ GPS cover 2 pcs | |
| ⑧ Motor accessories: 6 bags | | | |

2. Take out the landing gear sets and assemble as per Figure 2. Assembly completes as shown Figure 3.

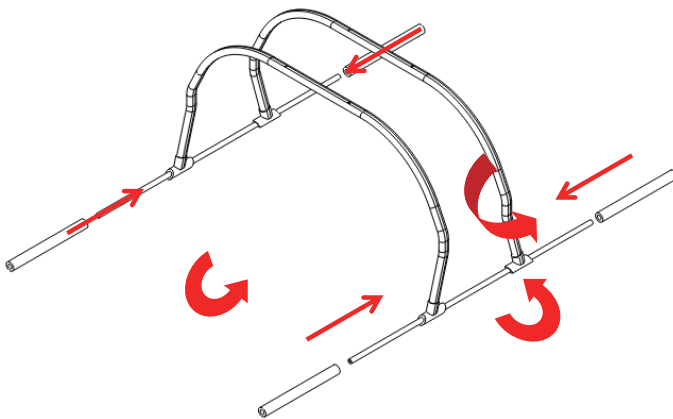

(Figure 2)

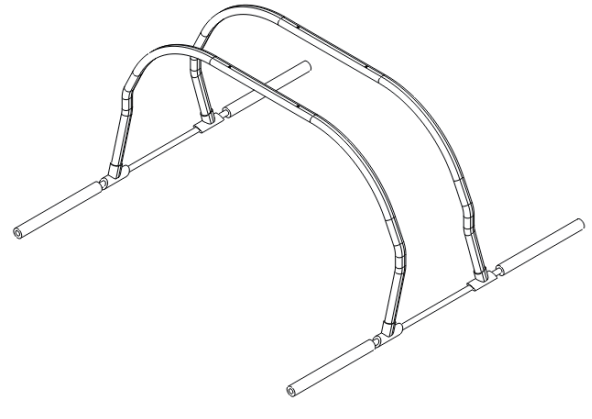

(Figure 3)

3. Unscrew the nut (Figure 4) and fix the landing gears to the frame. (Figure 5)

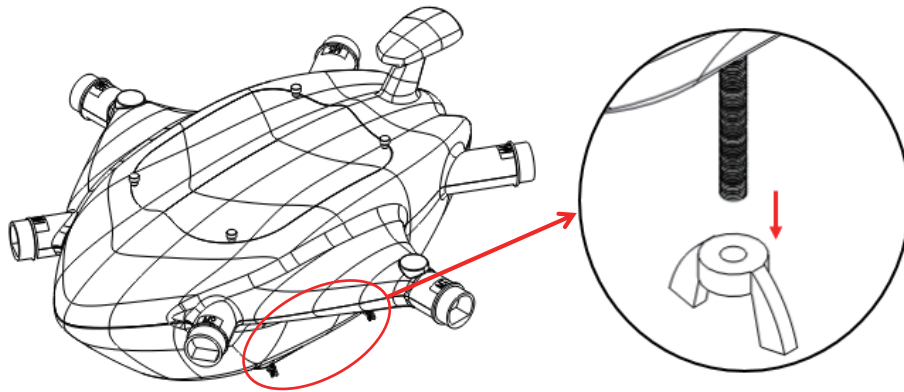

(Figure 4)

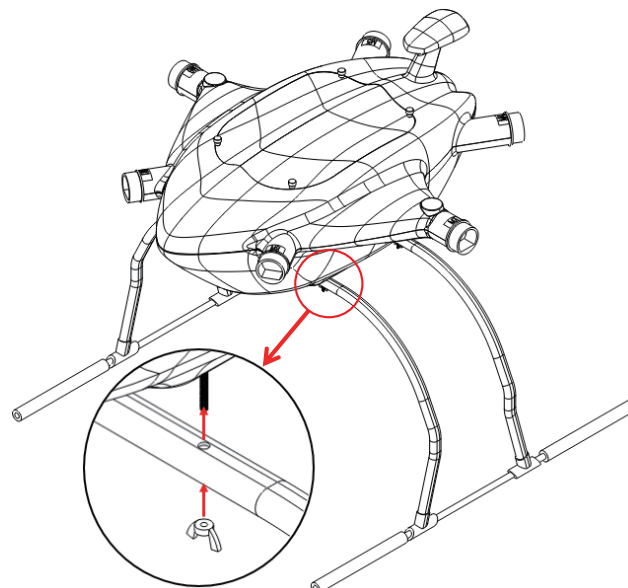

(Figure 5)

07 FC INSTALLATION (Pixhawk 2)

1. Assemble the FC as per Figure 6.

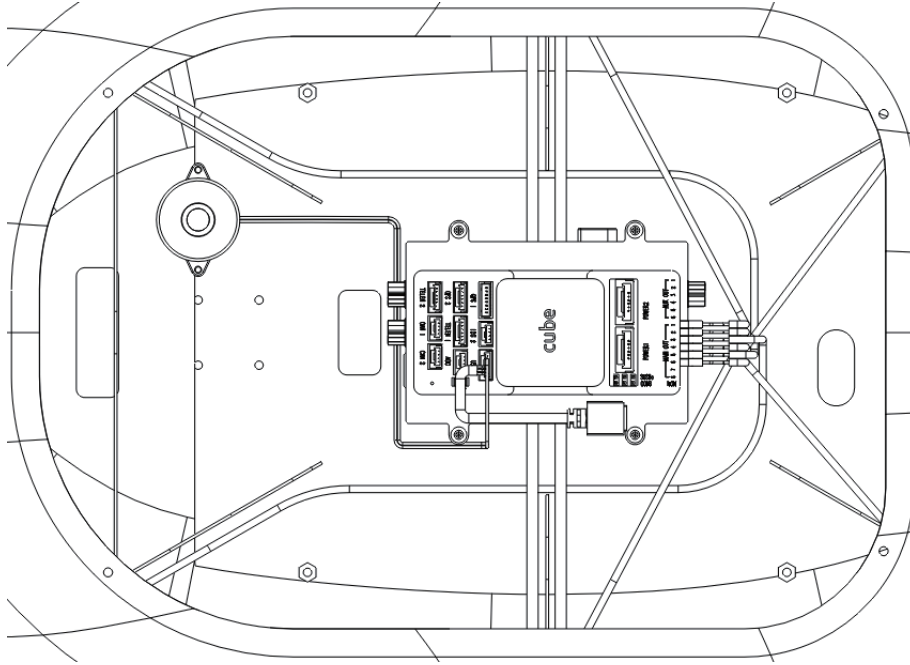

(Figure 6)

2. Fix the image transmission onto the bottom of the frame, and attach the antenna to the frame with 3M tapes as shown Figure 7.

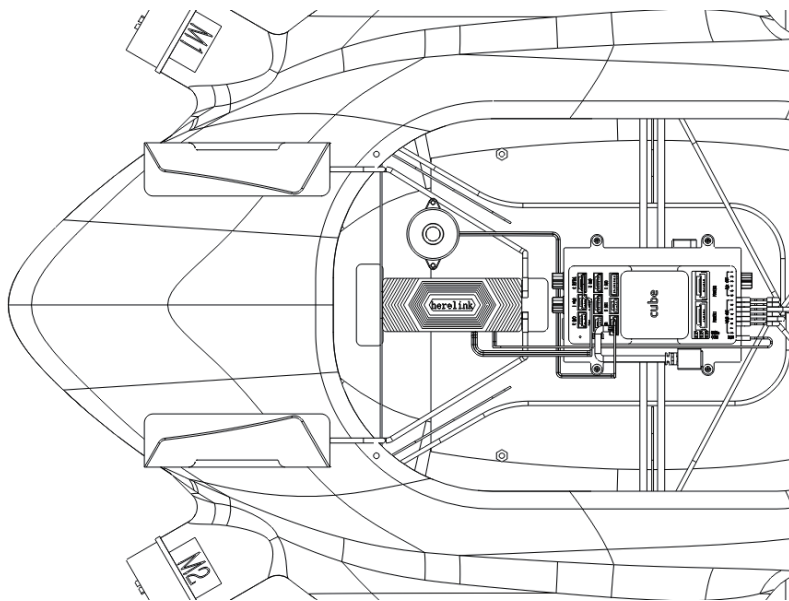

(Figure 7)

3. Stick the GPS with a 3M tape to the holder and fix the holder onto the body. (Figure 8)

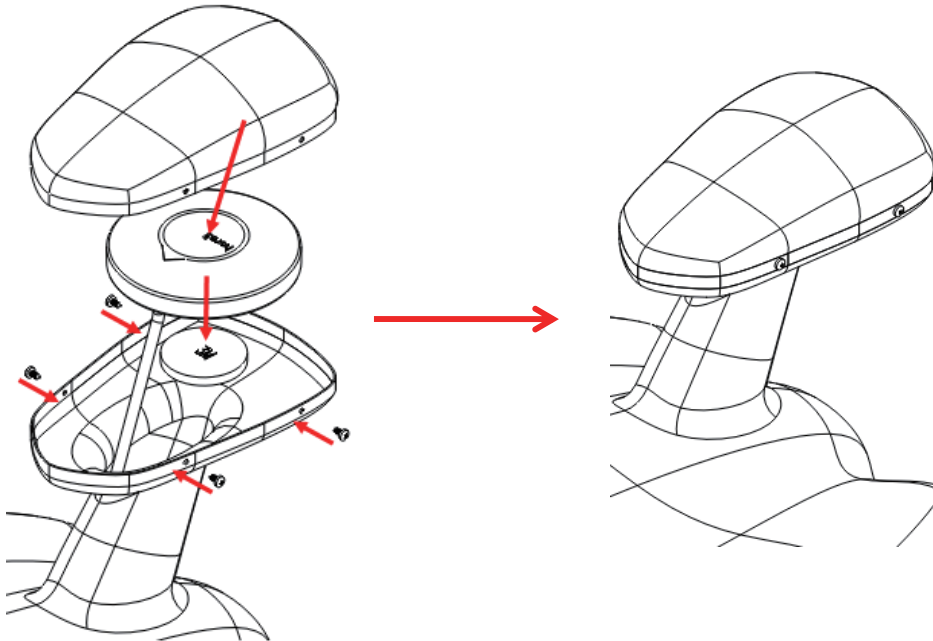

(Figure 8)

4. Put in the arms to the frame as per the indications and secure them with the locking rings. (Figure 9)

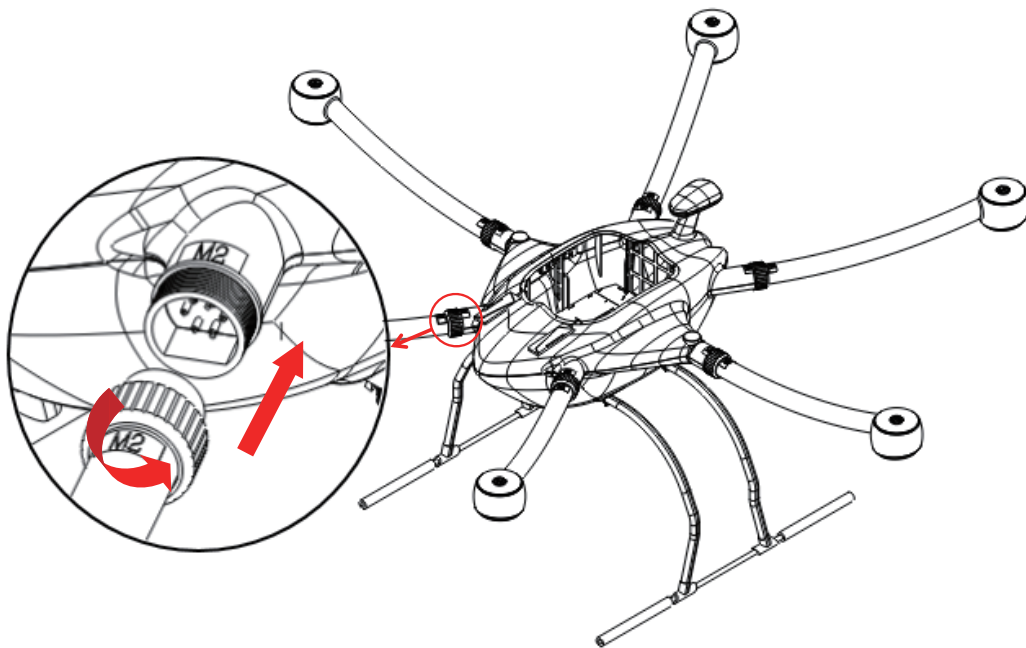

(Figure 9)

4. Install the propellers as per Figure 10 after calibration of the FC. Propeller installation completed as shown Figure 11.

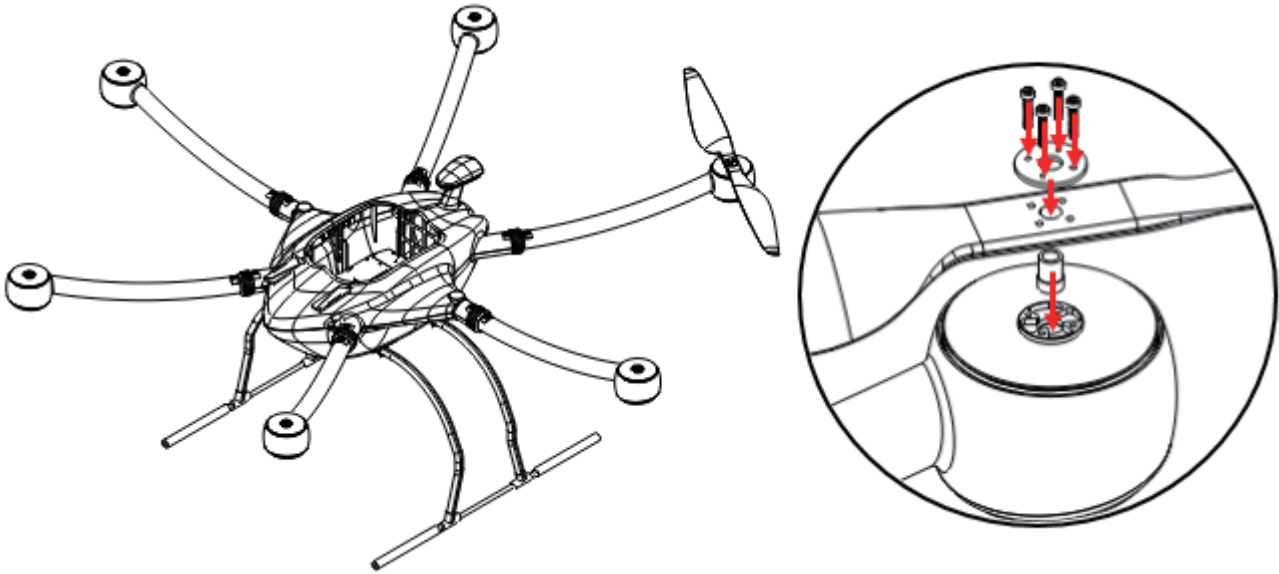

(Figure 10)

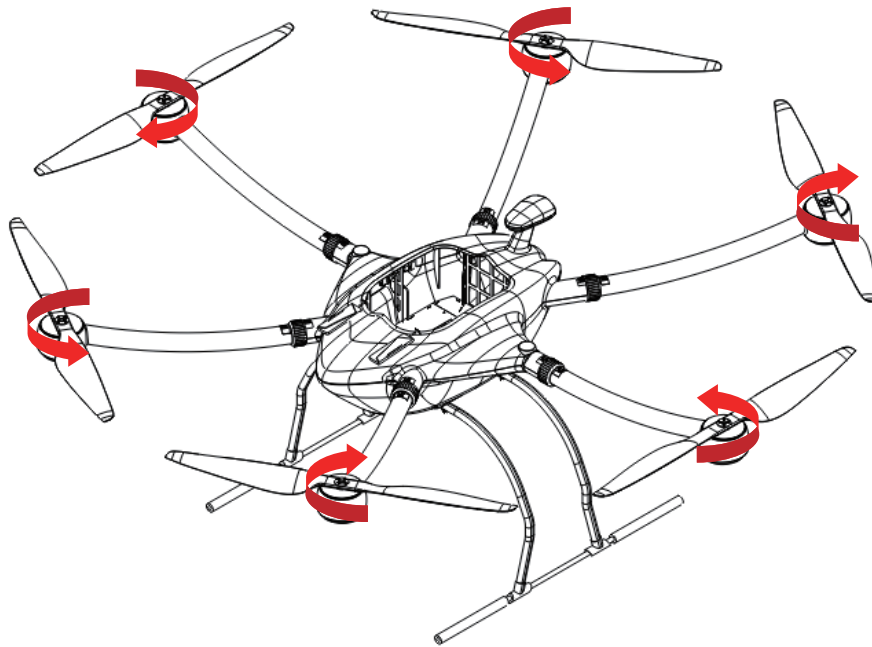

(Figure 11)

09 DIMENSIONS

1. Wheelbase (Figure 13)

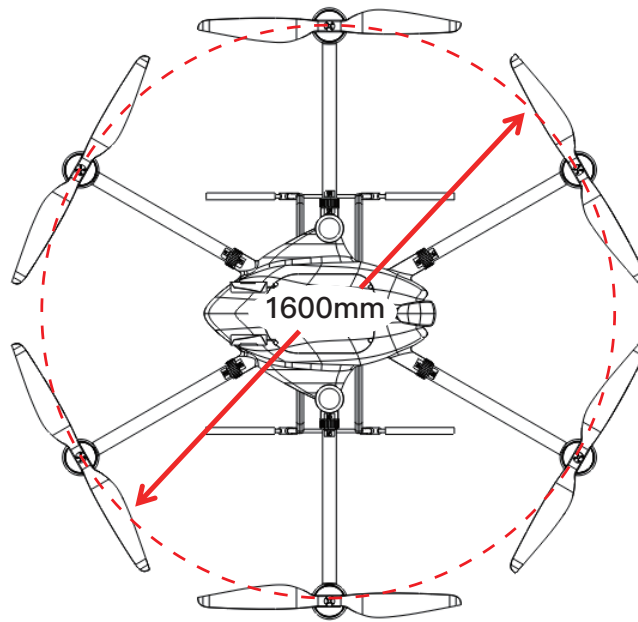

(Figure 13)

2. Other Sizes (Figure 12)

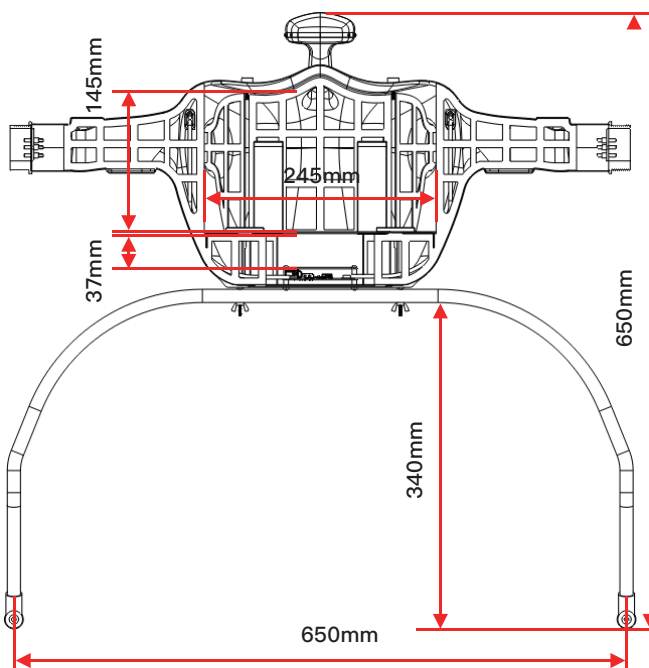

(Figure 14)

- ① Flight control installation height: 37mm
- ② Battery cell size: 245*145mm
- ③ Landing gear wide: 650mm
- ④ Mounting height of gimbal: 340mm
- ⑤ Total altitude of UAV: 650mm

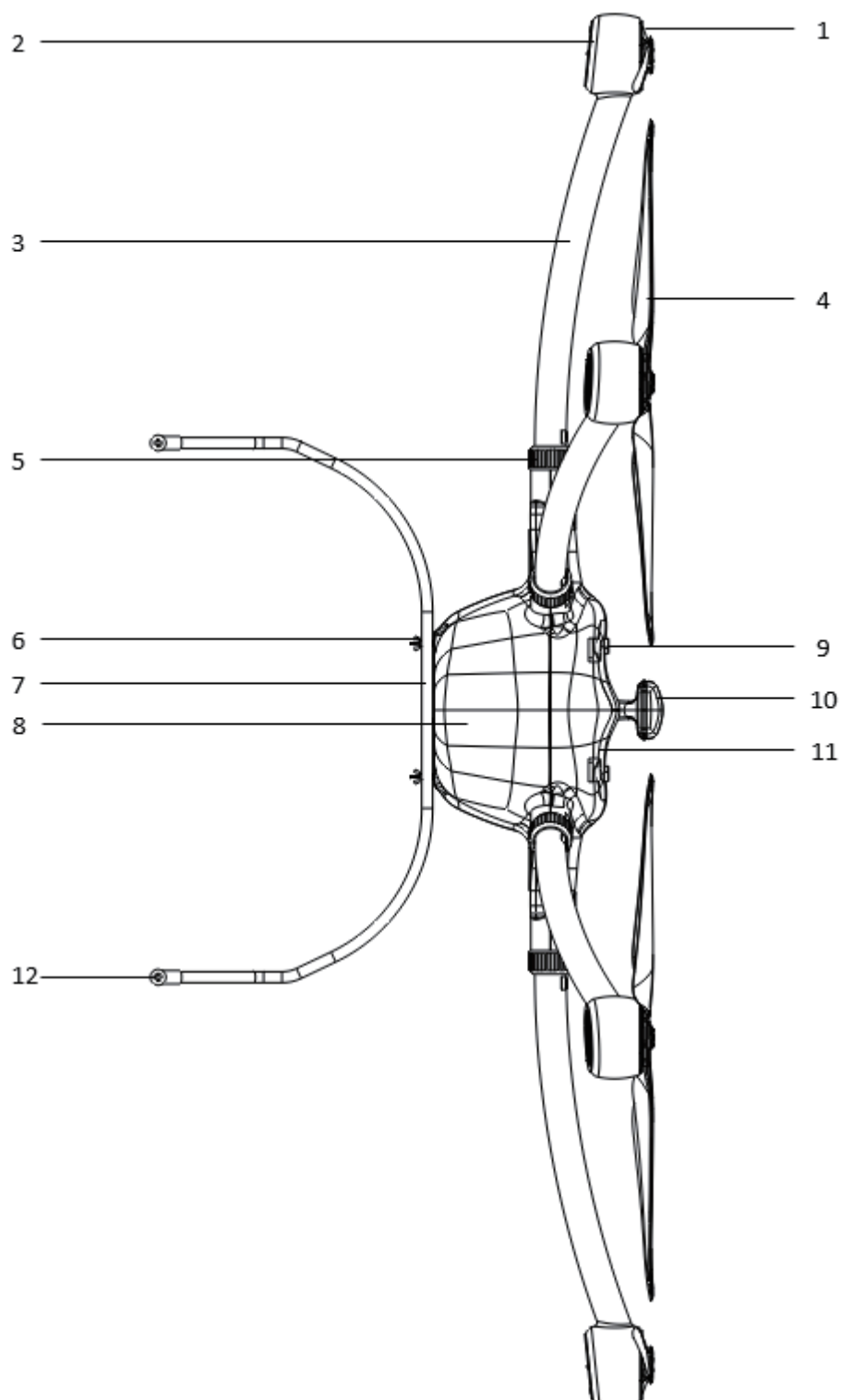
08 COMPONENTS(Figure 12)

(Figure 12)

- | | | | | | | |
|----------|--------------|---------|-----------------|--------------------|--------|-----------------|
| 1. Motor | 2. LED cover | 3. Arm | 4. Propellers | 5. Locking rings | 6. Nut | 7. Landing gear |
| 8. Frame | 9. Screw | 10. GPS | 11. Upper cover | 12. Shock absorber | | |